



morton.

Crows Nest 40/13 Ernest Street

🛏 1 🚗 1 🚗 1

Combining a superb setting in the heart of Crows Nest with a low maintenance lifestyle of rarely surpassed convenience, this light filled 'Village Green' apartment presents an exciting opportunity for anyone keen to secure a foothold in this sought after north side suburb.

- Spacious open plan living flows to balcony with northerly aspect
- Modern gas kitchen with granite bench-top and dishwasher
- Double-sized bedroom fitted with mirrored built-in wardrobe
- Internal laundry, large lock-up garage, visitor car spaces
- Well maintained building with security intercom and lift access
- Footsteps from Crows Nest Village and a stroll to the new Metro line

View

As advertised or by appointment

Agents

Konstantin Melnikov

📞 0421 540 424

✉ konstantin@morton.com.au

Ferenc Goemoeri

📞 0447 025 423

✉ ferenc@morton.com.au

morton.com.au

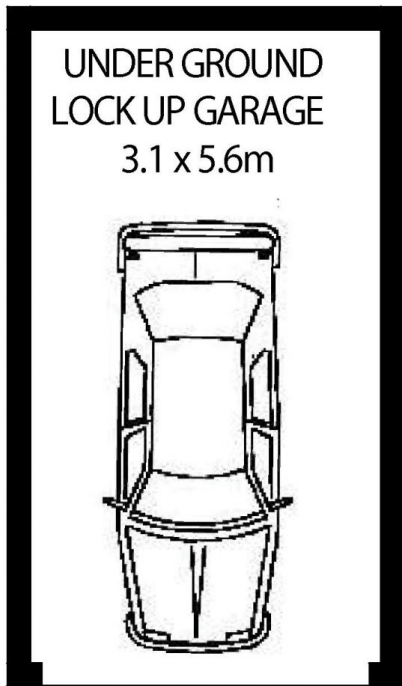

BASEMENT LEVEL TWO

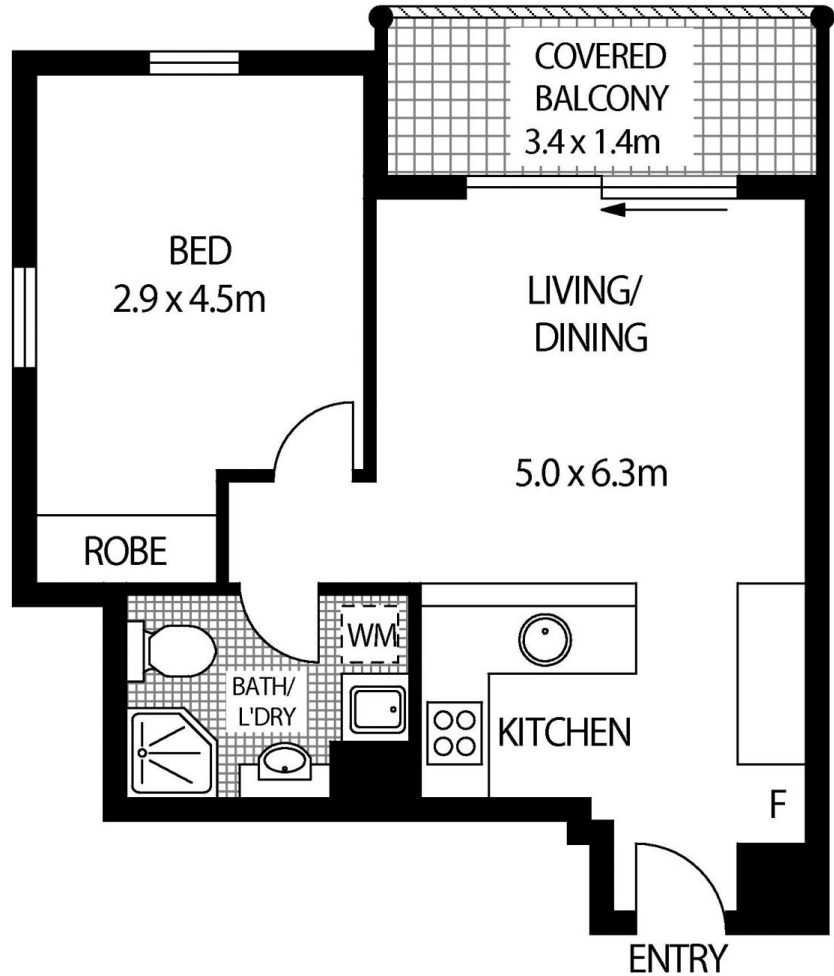

LEVEL TWO



40/13 ERNEST STREET

CROWS NEST

SCAPE Floor Planing Disclaimer: This floor plan is conceptual only. It is provided for illustrative purposes only and should not be relied upon. We make no guarantee as to the correctness of this plan. All interested parties should make and rely on their own enquiries in determining the accuracy of the information contained in this floor plan.