



morton.

Pyrmont 223/102 Miller Street

 2  2  1

Offering a contemporary lifestyle opportunity in a highly sought-after community, this spacious residence boasts a long list of impressive features that is sure to tick all the boxes. Featuring a seamless layout that stylishly combines open plan living with tranquil leafy views making it perfect for the investor or a family home.

- Spacious granite kitchen equipped with gas cooktop and ample bench space
- Full main bathroom, ensuite and separate internal laundry and powder room
- Two generous sized bedrooms, all fitted with built-in wardrobes
- Access to a covered balcony from the living space
- Split system air-conditioning ensuring complete comfort year-round
- Resort style facilities including pool, gym, sauna, 24-hour reception and onsite security
- Walk to Miller Street cafes, vibrant pubs and world-class restaurants

View

As advertised or by appointment

Agents

Ian Qiu

 0447 696 425
 ian@morton.com.au

Naomie Texier

 0439 247 710
 naomie@morton.com.au

morton.com.au

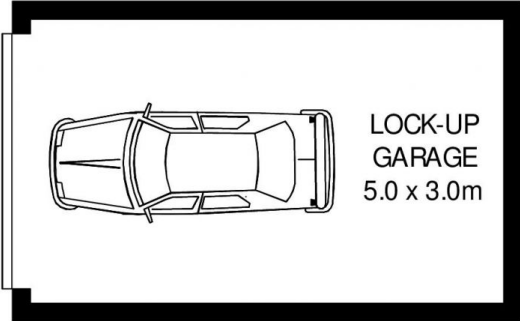

BASEMENT P2

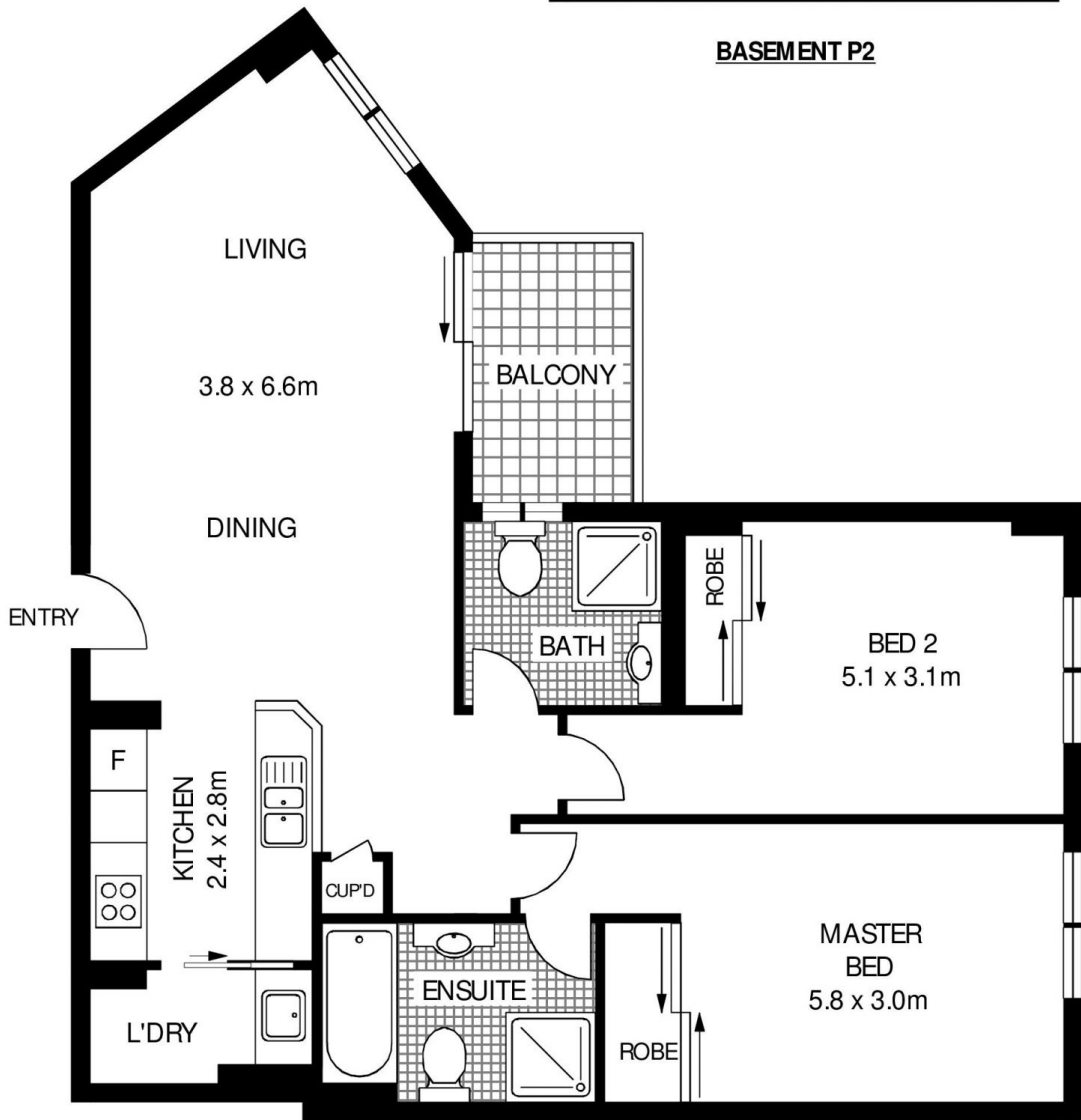

LEVEL 5



223/102 MILLER STREET

PYRMONT

SCAPE Floor Planning Disclaimer: This floor plan is conceptual only. It is provided for illustrative purposes only and should not be relied upon. We make no guarantee as to the correctness of this plan. All interested parties should make and rely on their own enquiries in determining the accuracy of the information contained in this floor plan.