



morton.

Penrith 106/101C Lord Sheffield Circuit

 1  1  1

A contemporary residence of the highest calibre, this designer apartment's streamlined design and features combine to create a home with wide ranging appeal. It makes an ideal choice for buyers seeking a high quality easy-to-maintain property that is private, secure and tucked away within the sought-after Thornton Estate community close to the heart of Penrith, with the train station and Westfield shopping 100m away.

- Split system air con in the living room with carpet throughout
- Spacious courtyard ideal for entertaining with secure street access
- Built in mirror robes to the good-sized bedroom
- Internal laundry with dryer, separate linen cupboard with good sized bathroom
- Omega appliances including oven, rangehood, dishwasher and microwave
- MATV and pay TV points in the living room and bedroom
- Secure car space and storage cage in the basement with lift access



morton.com.au

View



As advertised or by appointment

Agents

David Lipman

 0409 663 535
 david@morton.com.au

SJ Singh

 0417 085 519
 sj.singh@morton.com.au



NO'64

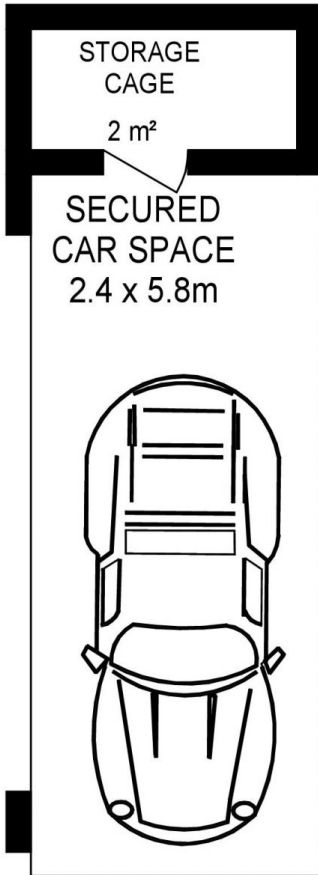

LEVEL B1

NO'20

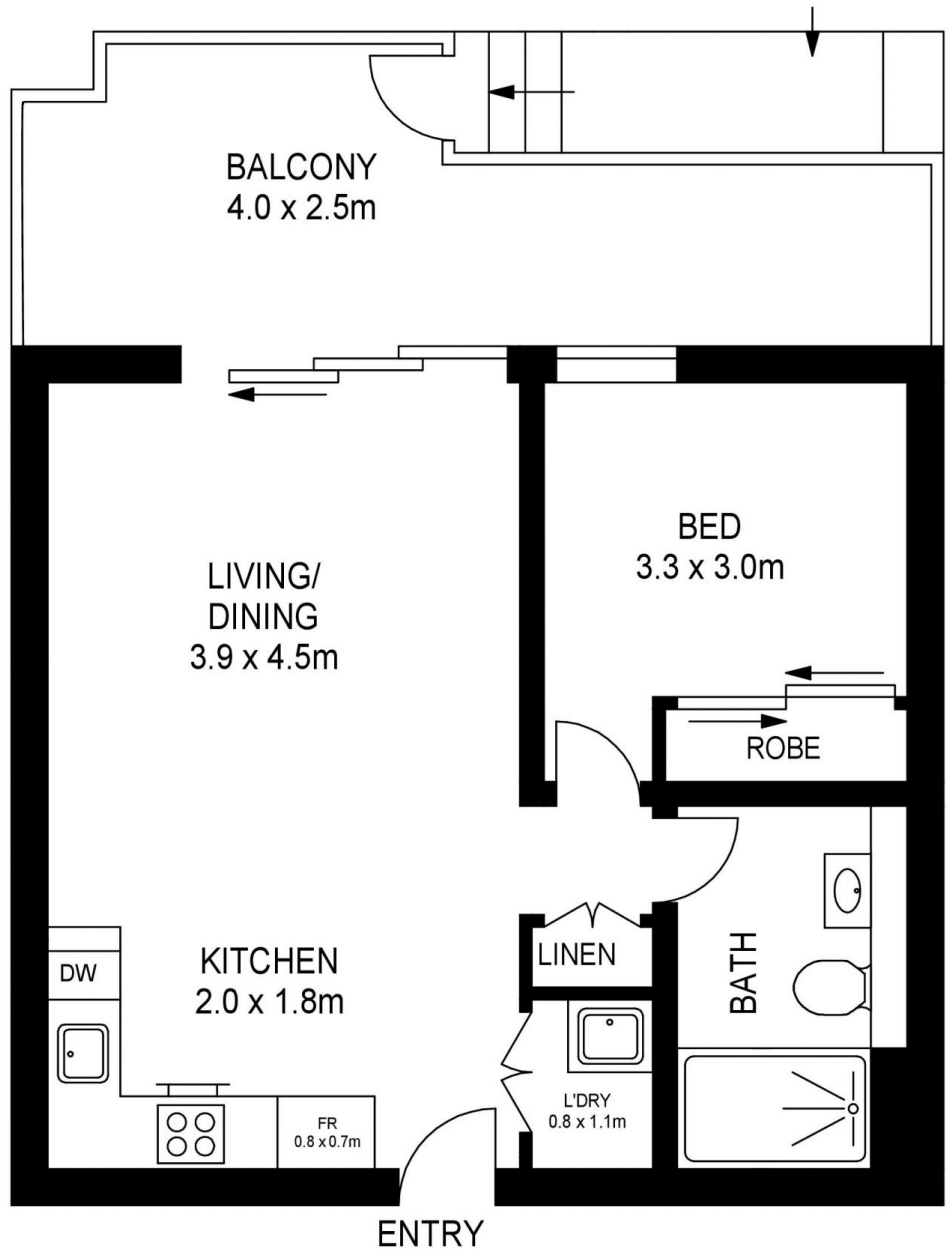

LEVEL ONE

APPROX. INT. AREA : 49 m²
 APPROX. EXT. AREA : 14 m²
 TOTAL AREA INCLUDING CAR SPACE & STORAGE CAGE : 79 m²

106/101C LORD SHEFFIELD CIRCUIT, PENRITH



www.assetphotographers.com.au

Please note these measurements are approximate only. The plans are intended as a rough guide for illustrative purposes. It is not warranted or guaranteed to be correct nor is it part of the sale or rental contract.