



# morton.

**SYDNEY** 317/45-49 Shelley Street

 1  1  1

A rare opportunity to reside in one of King Street Wharfs apartments. Located within a short stroll to the city centre, vibrant Cockle Bay and Darling Harbour this unfurnished one bedroom apartment offers excellent space, great natural light and contemporary living.

Fresh interiors, quality finishes and ample space come together to create this urban oasis. Ideal for the busy professional.

- One bedroom with built-in robe
- Cleverly designed separate study
- Open plan living and dining area
- Modern kitchen with breakfast bar
- Bathroom and internal laundry
- Reverse cycle air conditioning
- Secure building
- Secure car space

### View

As advertised or by appointment

### Agent

**Morton**

 [info@morton.com.au](tel:)

[morton.com.au](http://morton.com.au)

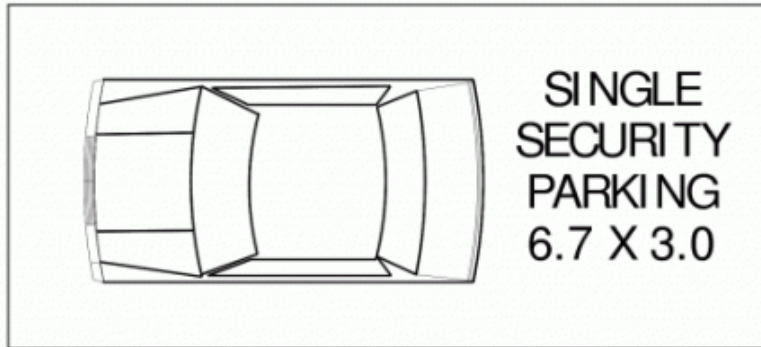

BASEMENT FLOOR

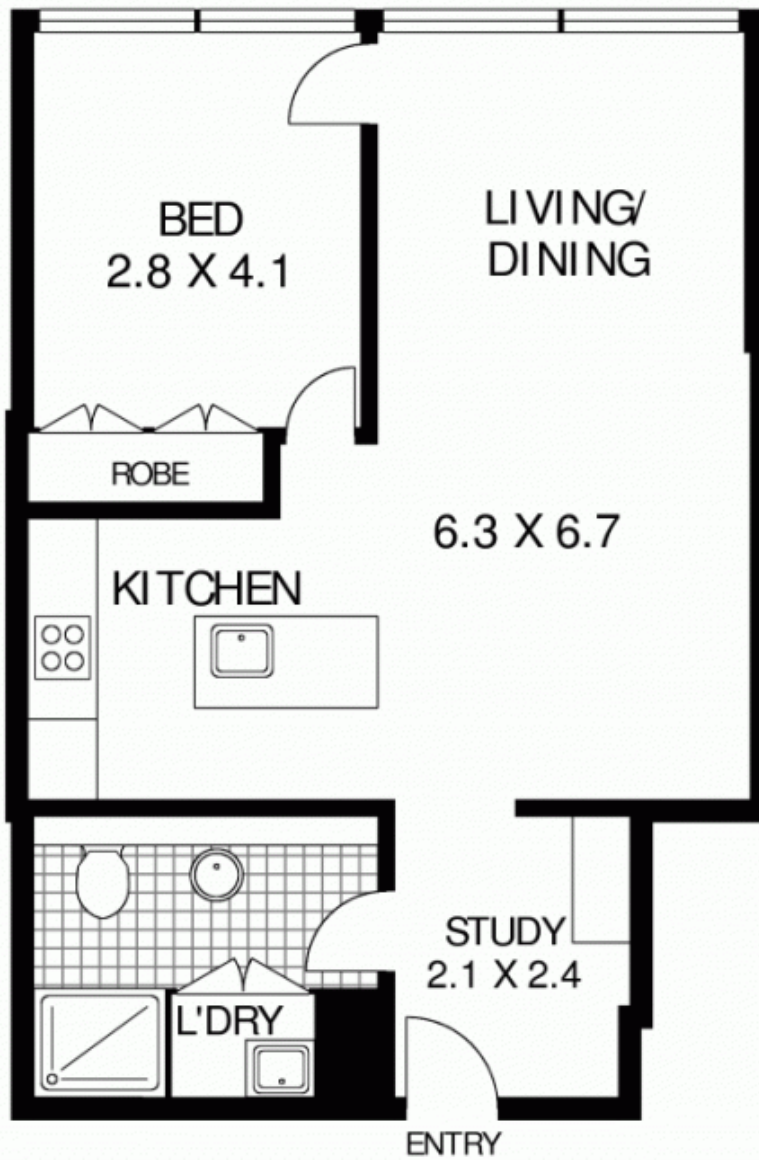

SECOND FLOOR



**317/ 49 SHELLEY STREET**

**SYDNEY**

**SCAPE Floor Planning Disclaimer:** This floor plan is conceptual only. It is provided for illustrative purposes only and should not be relied upon. We make no guarantee as to the correctness of this plan. All interested parties should make and rely on their own enquiries in determining the accuracy of the information contained in this floor plan.