



morton.

Woolloomooloo 301/6 Cowper Wharf Roadway

 1  1  1

This modern and sophisticated one bedroom apartment is located on the coveted Heritage level of the iconic Woolloomooloo Finger Wharf building. Bathed in sunlight, soaring ceilings and the original beams and braces makes this an ideal city pad.

- City and marina views from living room and bedroom
- Stylish gas kitchen is complete with granite benches
- Bright open plan living, exquisite American Oak timber floors
- Master bedroom with built-in wardrobes
- Reverse cycle Air-conditioning, internal laundry
- 24 hour security on site, with video intercom
- Secured parking in Lincoln Crescent

View

As advertised or by appointment

Agent

Sarah Fowell



 sarah@morton.com.au

morton.com.au

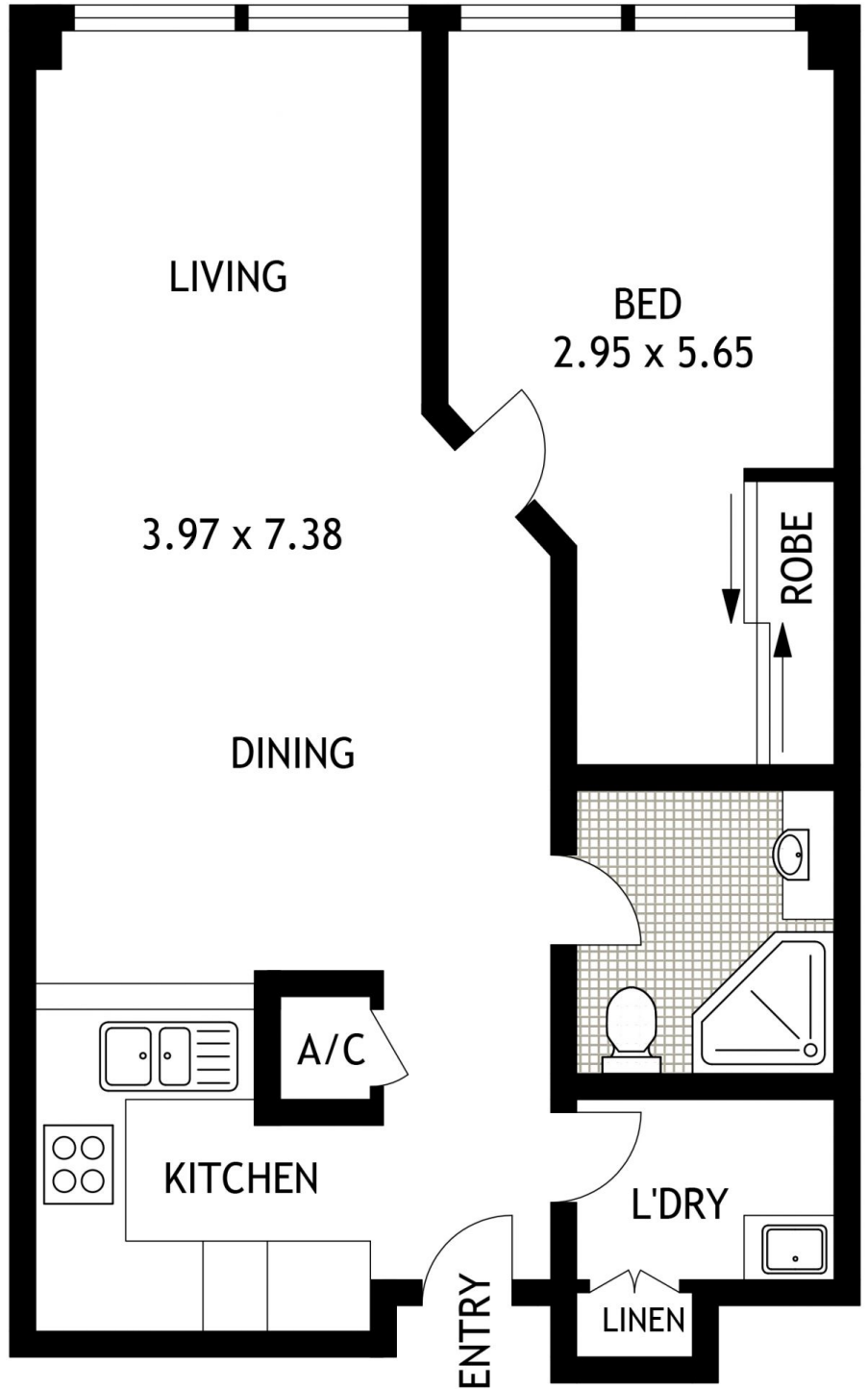
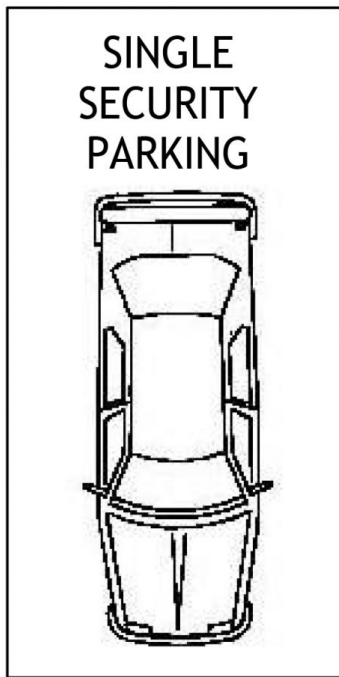

THIRD FLOOR



301/6 COWPER WHARF ROAD

WOOLLOOMOOLOO

SCAPE Floor Planning Disclaimer: This floor plan is conceptual only. It is provided for illustrative purposes only and should not be relied upon. We make no guarantees to the correctness of this plan. All interested parties should make and rely on their own enquiries in determining the accuracy of the information contained in this floor plan.