



morton.

Pyrmont 1002/32 Refinery Drive

 3  2  2

Bathed in the light of a northern aspect and opening to embrace spectacular views across the water, Balmain peninsula & Harbour Bridge, this exceptional harbourfront residence is a masterpiece of modern design. Immaculately maintained with a superior attention to detail, this is an offering of undeniable quality.

- Private and quiet with only two apartments per floor
- Intuitive configuration with open entertaining areas
- Sunny master with ensuite, built-ins and water views
- Custom ultra modern designer finished kitchen
- Spacious BBQ balcony is awash with natural sunlight
- Ducted air conditioning, pool, spa and storage cage
- With access to two pools, spa, gym, two tennis courts

View

As advertised or by appointment

Agent

Sarah Fowell

 0437 492 129

 sarah@morton.com.au

morton.com.au



BASEMENT

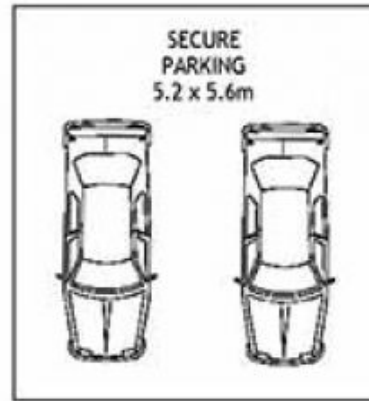

BASEMENT



LEVEL TEN



1002/32 REFINERY DRIVE

PYRMONT

ICAPE Floor Planning Disclaimer: This floor plan is conceptual only. It is provided for illustrative purposes only and should not be relied upon. We make no guarantees to the correctness of this plan. All interested parties should make and rely on their own enquiries in determining the accuracy of the information contained in this floor plan.