



morton.

ULTIMO 412/99 Jones Street

 1  1  1

INSPECTION CANCELLED - UNDER APPLICATION

** Please register your details for our inspections to be kept up to date with the property status. All available inspection times will be automatically emailed to you by completing the online inquiry form below, or "Book Inspection" directly at www.mortonandmorton.com.au/9221823

View

As advertised or by appointment

Agent

Morton RE

 rentals@morton.com.au

morton.com.au

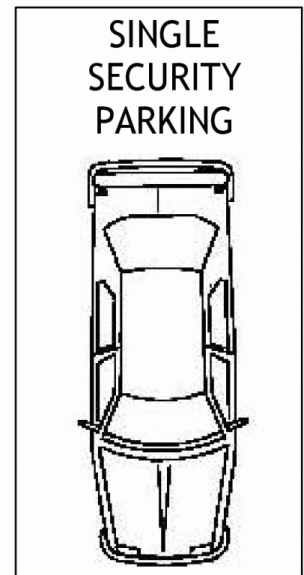
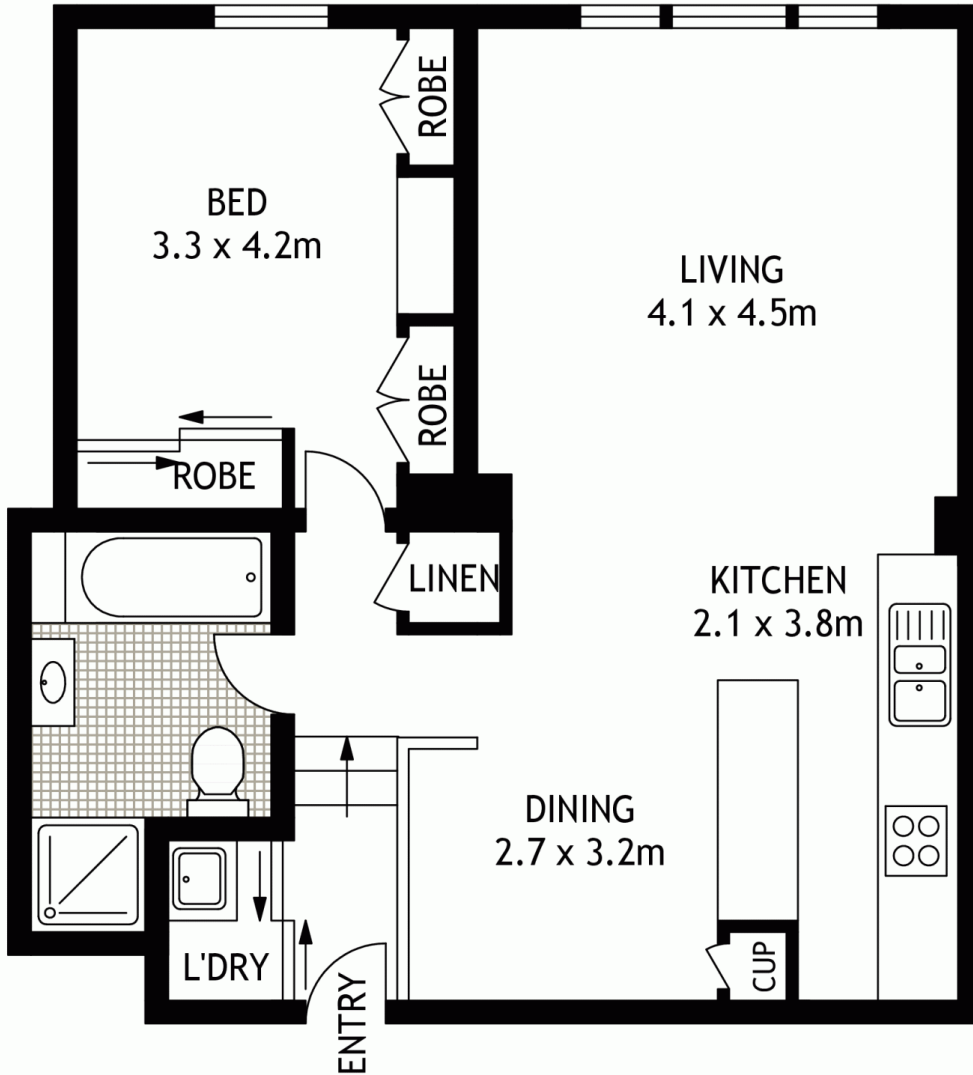

FOURTH FLOOR

412/99 JONES STREET

ULTIMO

SCAPE Floor Planing Disclaimer: This floor plan is conceptual only, it is provided for illustrative purposes only and should not be relied upon. We make no guarantees to the correctness of this plan. All interested parties should make and rely on their own enquiries in determining the accuracy of the information contained in this floor plan.