



morton.

CROWS NEST 12/10 Brook Street

 1  1  1

Full of natural light, this comfortable apartment offers a fresh and easy care home of light and convenience. Set within a well maintained security complex, it presents a great buying opportunity for those looking for a quality property with excellent style and convenience.

- Bright and breezy interiors with an open living space
- Freshly painted throughout with scope for improvement
- Wraparound balcony, security car space, visitor parking
- Good sized double bedroom and large mirrored built-ins
- Swimming pool, BBQ area and games room in complex
- Great investment with solid growth and rental potential
- Currently vacant

View

As advertised or by appointment

Agent

Sarah Fowell

 0437 492 129

 sarah@morton.com.au

morton.com.au

12/10 Brook Street, CROWS NEST

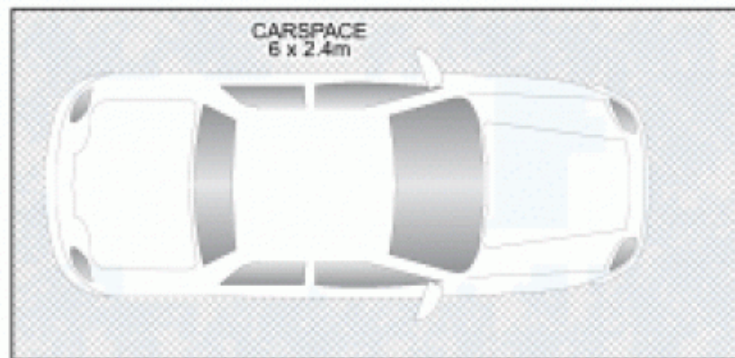
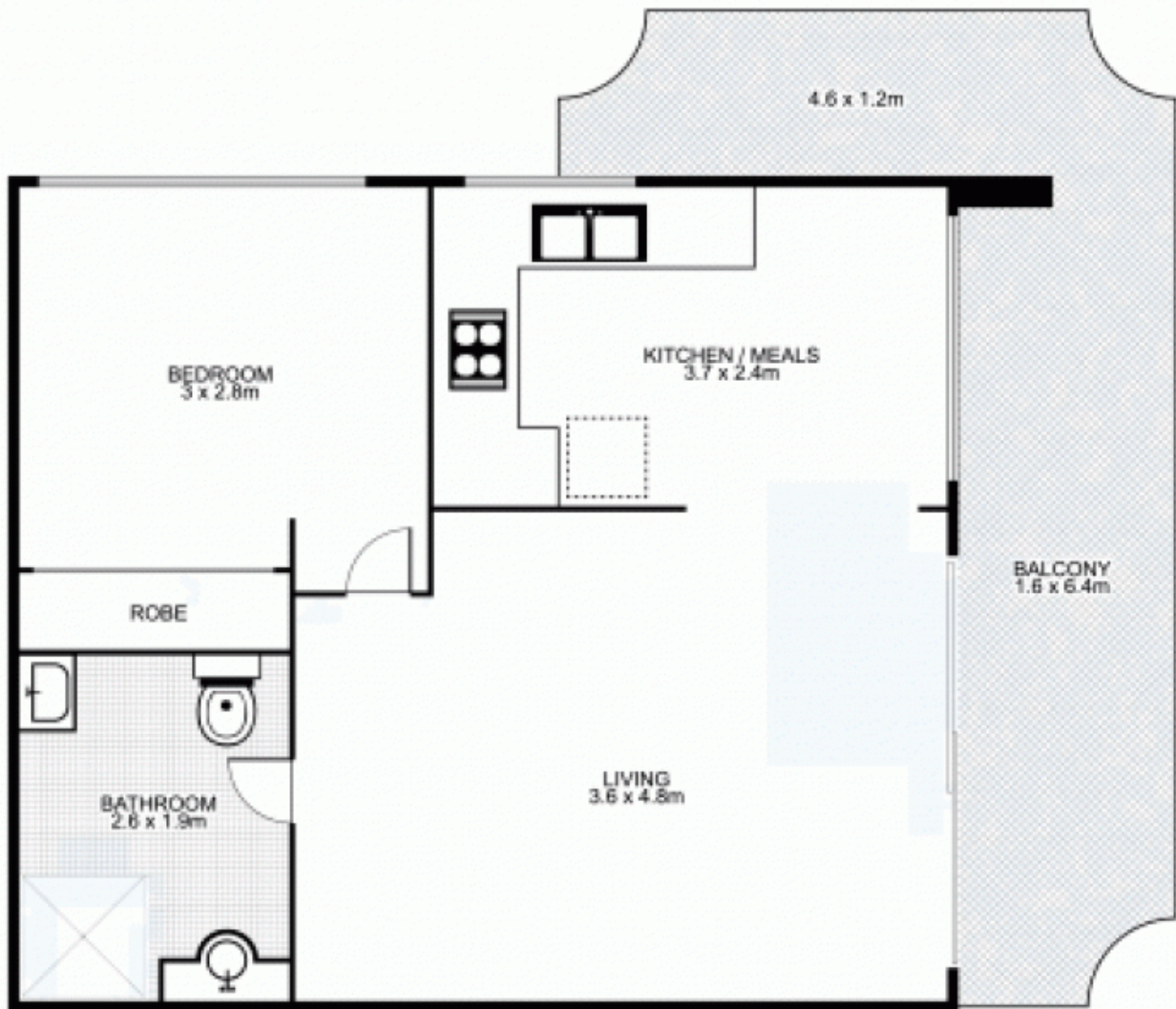

This floor plan is intended as a guide only. Layout dimensions are approximate only. No representation or warranties of any nature whatsoever are given or intended. Any person using this information should rely on their own enquiries.