



**morton.**

**Sydney** 317/49 Shelley Street



Take advantage of the idyllic 'King Street Wharf' lifestyle with this super convenient apartment featuring fresh interiors, quality finishes and ample storage space, coming together to create this urban oasis. This apartment is ideal for the discerning professional seeking an executive retreat.

- One bedroom unfurnished apartment
- Built in wardrobes
- Cleverly designed floor plan, separate study
- Open plan living and dining area
- Modern kitchen with breakfast bar
- Bathroom and internal laundry with dryer included
- Reverse cycle air conditioning
- Security building
- Secure underground car space

**View**

As advertised or by appointment

**Agent**

**Morton RE**



rentals@morton.com.au

**morton.com.au**

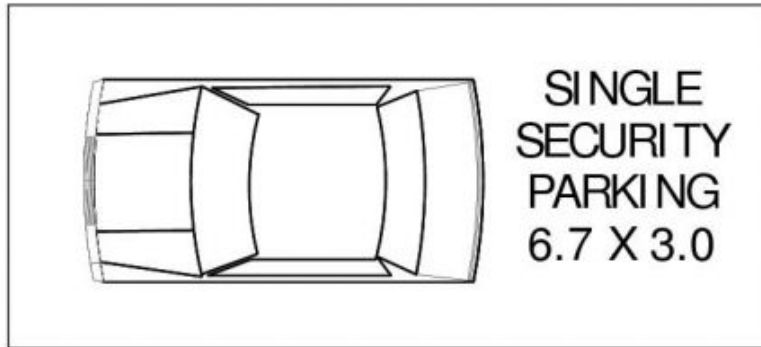

BASEMENT FLOOR

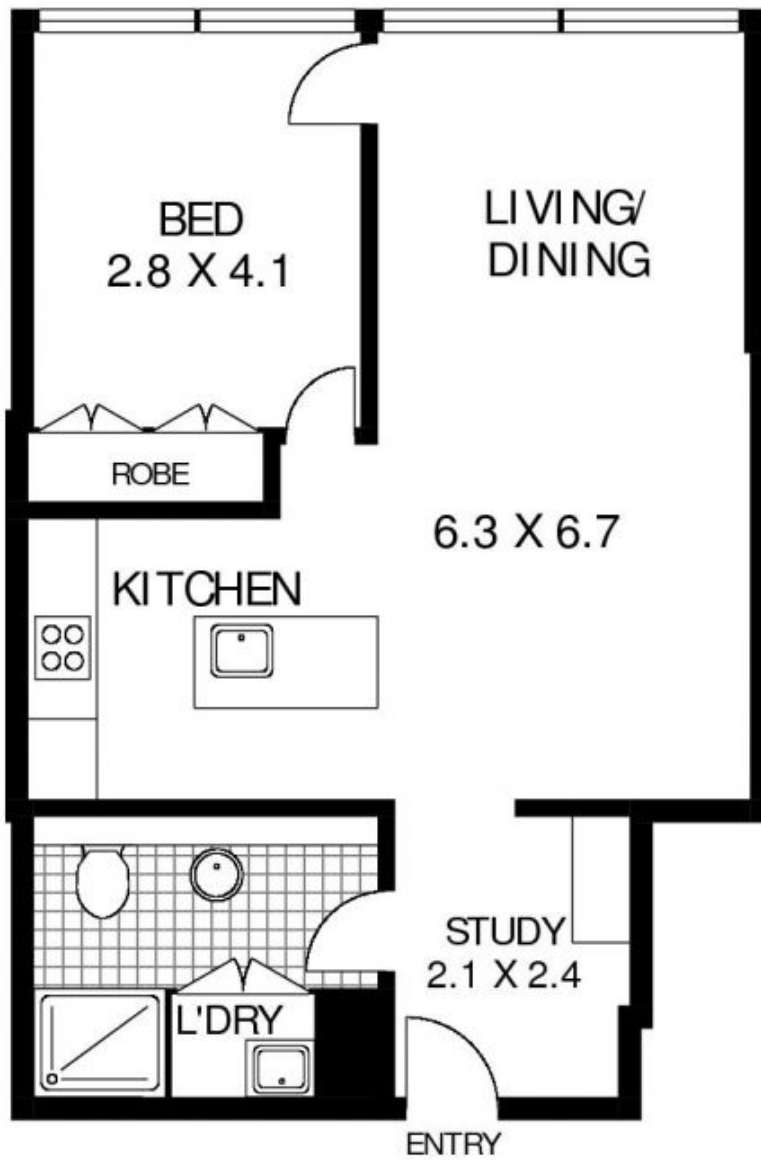

SECOND FLOOR



**317/ 49 SHELLEY STREET**

**SYDNEY**

**SCAPE Floor Planning Disclaimer:** This floor plan is conceptual only. It is provided for illustrative purposes only and should not be relied upon. We make no guarantee as to the correctness of this plan. All interested parties should make and rely on their own enquiries in determining the accuracy of the information contained in this floor plan.